



DELHI. MUMBAI. BANGLORE. PUNE. INDORE. HYDERABAD. CALIFORNIA

Salon Chair with Hairdresser Seat

IDENTIFYING LICENSEES

Introduction

- A hairdresser spends more than 60% of working time standing
- About half of the life they spend in standing position
- Being on feet for long time daily leads to various health complications
- Almost 60 – 70 % hair dressers are suffering from various health problems due to long standing hours

Long Standing - Complications

➤ Varicose Veins

Varicose veins are veins that have become enlarged and twisted, especially within the legs, ankles and feet of an affected individual. If this swollen vein got hit by something bleeding starts with the high pressure.



➤ Carotid Atherosclerosis

Standing for long periods can change the distribution of blood in the extremities. This in turn causes the blood to pool and reduces the circulating blood plasma volume leading to hemodynamic changes that impact the body.

➤ Joint Compression

Standing places significant pressure on the joint of the hips, knees, ankle and feet but without any significant movement of it. This reduces the normal lubrication and cushioning of synovial joints, causing them to tear.

➤ Muscle Fatigue

Muscles kept in a constant stress position quickly become exhausted and can result in pain and swelling in the lower back, legs, ankles and feet.

➤ Slouching

Slouching is often times described as improper posture, movement or rigidity of the spine, especially the cervical and thoracic regions, in relation to other parts of the body.

Proposed Technology

- A salon chair on which hairdresser can sit along with customer



Technology Overview

- Proposed chair provides a hairdresser's seat revolving around the chair and an auxiliary revolving seat attachment for the existing hydraulic chairs for allowing barber or hairdresser to work whilst seated wherein said seat is adjusted cantileverly.
- The chair comprises a base, a hydraulic system for raising or lowering a customer's seat and a revolving seat system adapted between the base and a hydraulic system.
- The chair has a footrest that allows the hairdresser to rest his/her feet and revolve the seat in any direction as per his/her wish for performing duty.

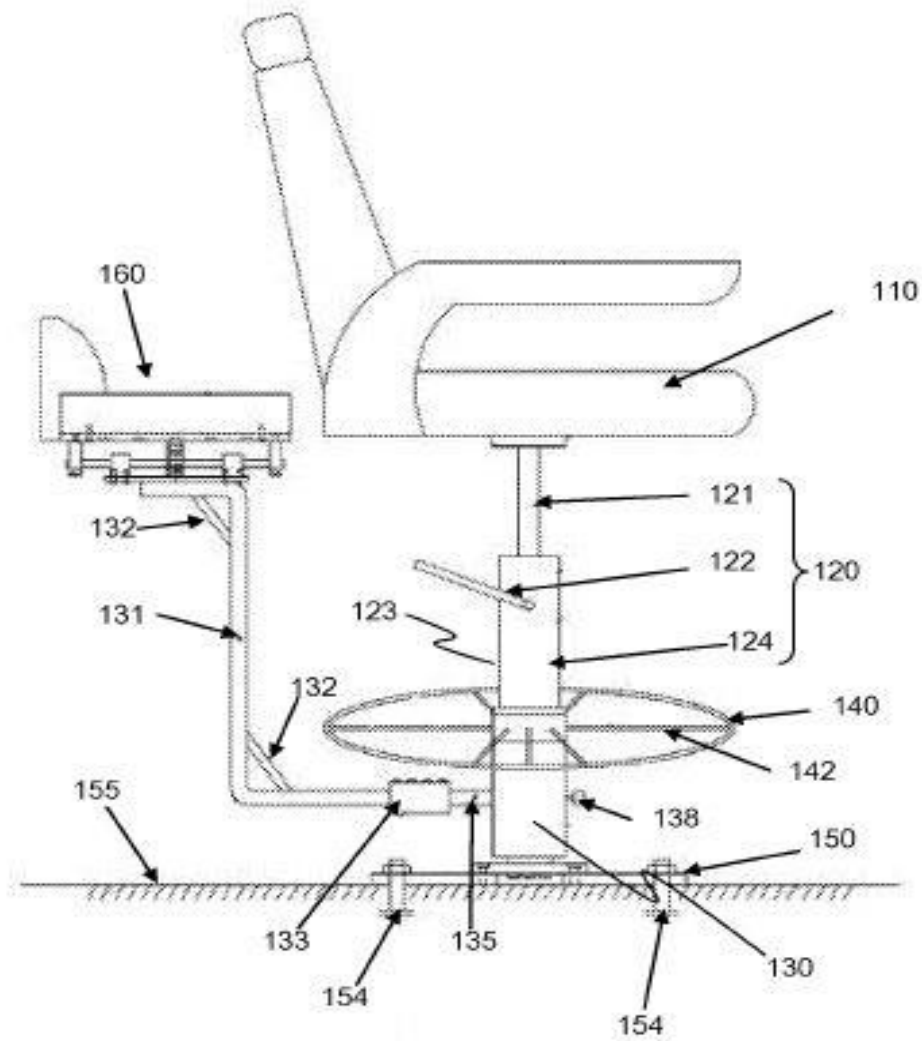

- 110 Customer Seat
- 120 Hydraulic System
- 121 Hydraulic Shaft
- 122 Lever
- 123 Stationary Cylinder
- 124 Hydraulic Pump
- 130 Revolving Seat System
- 131 Z – Shaped Rod
- 132 Reinforcing Bars
- 133 Sleeve
- 135 Connecting Bar
- 138 Speed Adjustment Knob
- 140 Footrest
- 142 Bars
- 150 Base
- 154 Bolt
- 155 Floor
- 160 Barber Seat



Product Features

- By using this special chair, hairdresser will not have to suffer from various problems.
- Hairdresser and customer chair can rotate 360 degree.
- Special attachment of hydraulic pump, customer chair height can be adjusted as per the customers requirement.
- Push back system is available for customer sitting chair.
- Locking system is provided for hairdresser sitting chair.
- Speed of rotation of hairdresser chair can be adjusted.
- For provision of extra height to the customer sitting chair height booster system is provided.
- Back rest system is available for hairdresser sitting chair.
- Zero maintenance cost.

Market Growth Forecast (India)

- Driving factors
 - Growing purchasing power of the Indian middle class
 - Increased spending on lifestyle needs
 - Favorable demographic age profile
 - Swelling urban population
 - Increasing awareness of grooming among men
- On the basis of revenue generated bigmarketresearch.com analysts forecast the Professional Salon Care market in India to grow at a CAGR of 27.07 percent over the period 2014-2019.*

* Source: <http://www.technavio.com/report/professional-salon-care-market-in-india-2014-2018>

- KPMG Wellness Sector report released in April 2015 projected that the size of India's beauty and wellness market would nearly double to Rs 80,370 crore by 2017/18 from Rs 41,224 crore in 2012/13.**
- KPMG Wellness Report estimates that workforce requirements in the beauty and salon segment will grow from 3.4 million in 2013 to 12.1 million in 2022.**

**Source: <http://www.businesstoday.in/magazine/features/vlcc-clsa-everstone-kpmg-ac-nielsen-report/story/209609.html>

Market Growth Forecast (Global)

- Revenue growth in the beauty salon industry is expected to increase by 3.3 percent annually through 2017.#
- According to the Professional Beauty Association, the number of positions available in the beauty industry is expected to grow by 16 percent between 2010 and 2020.#

Source: <http://smallbusiness.chron.com/beauty-salon-industry-analysis-70660.html>

Present Network

➤ Dealers in India:

- Maharashtra- 28
- Karnataka- 14
- Tamil Nadu- 10
- Gujarat- 22
- Telangana- 05
- Andhra Pradesh- 13
- Kerala- 02

Expectations

- Investor/Applicant of the technology is interested in out licensing.

Patent / IP Status

- PCT patent application filed
- Application Number: PCT/IN2016/050147
- Publication Date: Nov 24, 2016
- Priority Date: May 19, 2015



DELHI. MUMBAI. BANGLORE. PUNE. INDORE. HYDERABAD. CALIFORNIA

Contact Details

Noida (NCR) Office

E-13, UPSIDC Site-IV, Behind Grand Venice, Greater Noida, 201308

Contact Person: Gaurav Giri

 (IN) +91 9760835046

 (IN) +91 120 4296878, 4909201, 2399113

E-Mail: iiprd@iiprd.com , info@khuranaandkhurana.com

Website: www.iiprd.com | www.khuranaandkhurana.com