

# PATENT SELL/LICENSING PROPOSAL

A SYSTEM AND METHOD FOR  
GENERATING AN AUDIO-VISUAL

PATENT # 473296

APPLICATION # 201921012207

INVENTOR: MR. ROSHAN SURESH  
MUNJWADKAR

## **Technical Field of Invention:**

Technical Field of the current invention pertains to Computer Science, wherein process for which Patent Application is filed tend to generate an audio-visual from the text.

## **Introduction:**

The current invention, with the help of software (Artificial Intelligence), will convert a book with a FICTION story to an animated video. Any fiction book has the below details mentioned in it:

**Character** – detailed description is provided for each character (description, appearance, looks, strength, behavior, nature, qualities, characteristics etc.)

**Place** – detailed description is provided for the places like a house, farms, fields, castles, forts, jungles etc (how the places look like, the area, the condition of the place etc.)

**Narration** – the story narration and the description of characters and places creates imaginary characters, places and story in the reader's mind



## Working:

The software (Artificial Intelligence) shall do the below tasks:

- Read the entire book
- Understand the story and plot
- Convert the characters mentioned in the story to animated characters as per the description provided in the story
- Determine male and female characters and provide voice accordingly
- Convert the places mentioned in the story to animated places as per the description provided in the story
- Convert the story to an animated movie with background music as per the situation

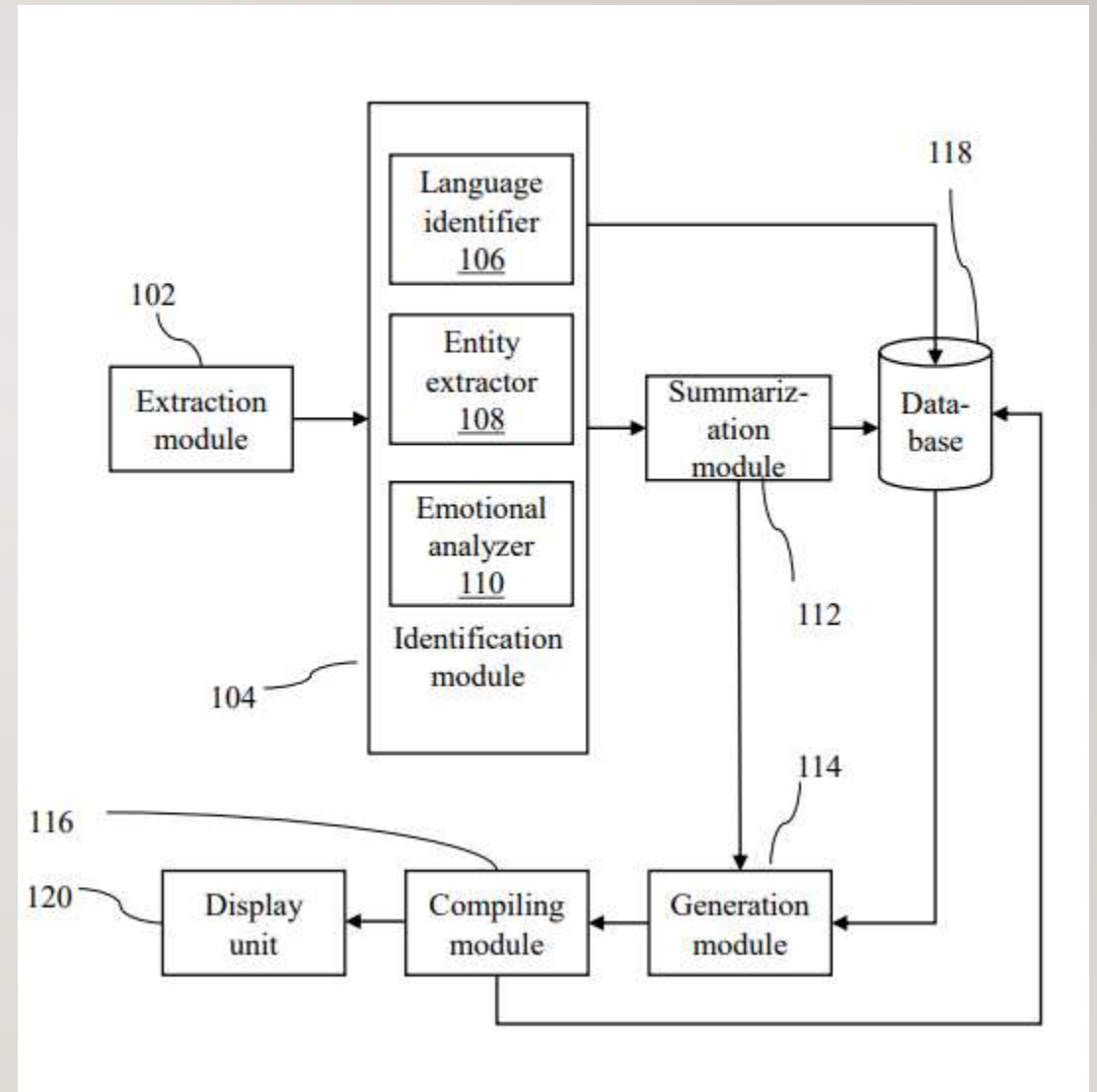

## Working (Contd.):

- Any sentences in inverted commas (“ ”) shall be considered as dialogues spoken by the characters.
- For the characters and places where description is not provided in the book, the artificial intelligence shall be able to create a closest accurate character and place (for example, common characters like Jesus, Krishna, etc. and places like heaven, hell etc. which requires no description, Artificial Intelligence shall be able to get the data from the internet and create a look alike character and place).
- This will make sure that the reader is watching the entire book as a movie and not spending much time

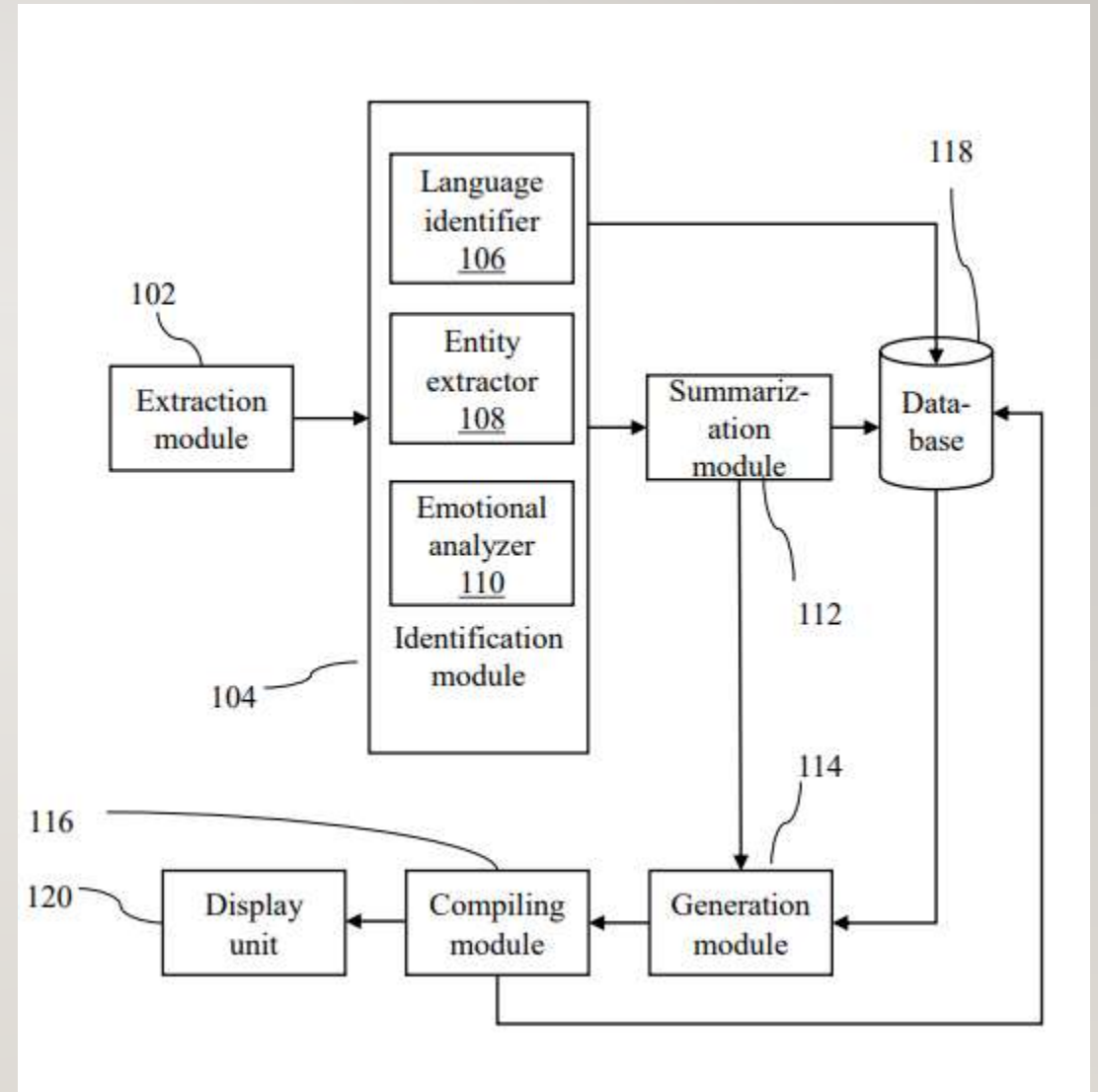



## Utility of Invention:

- Reading books is considered boring by major part of population as people are visually oriented and prefer getting the story through the action and visuals of a movie or video
- Many people like to listen to the story rather than reading
- Working people who love reading have to plan time to read books
- Most of the old aged people who love reading cannot read books due to vision problems
- Illiterate people cannot read books
- A book in a specific language can be read only by those people who can understand that language
- People do not have time to read books as per their priorities



## **Expectations:**

- Inventor seeks alliance with Potential Licensees to assign Licensing Rights.
- Inventor is also interested in Sale of the Patents.

## **Contact Details**

Roshan Munjwadkar

Email – [r.munjwadkar@rediffmail.com](mailto:r.munjwadkar@rediffmail.com)

Phone – 91 9890806632

Address – Flat#25, C/9 Nile CHS, Godrej Hill, Kalyan west, 421301, Maharashtra, India